

# DT-24A Dishwashing Trailer

## 1. Top View

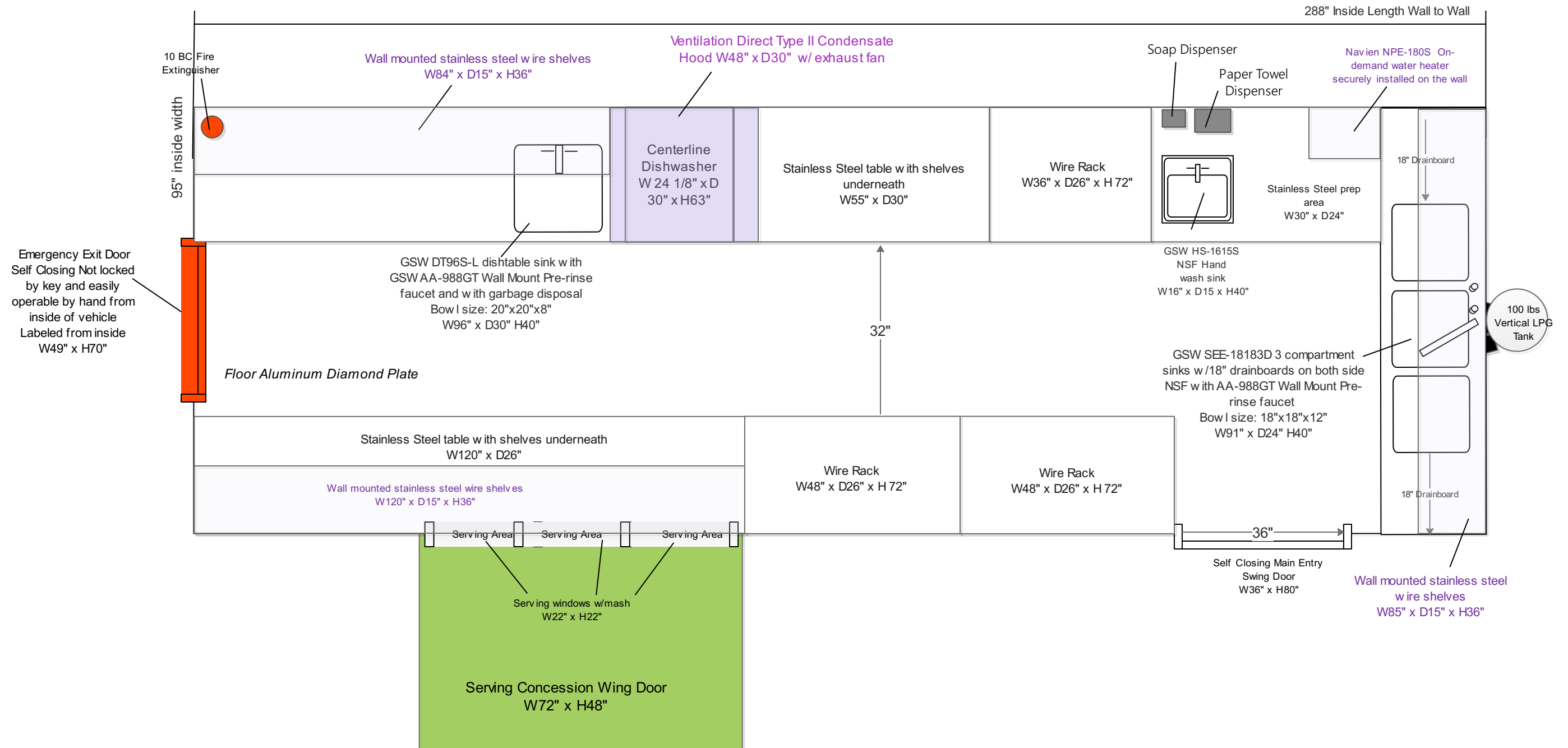

### Description:

- All submitted plans are scaled of 1/2"=1'
- 1/8" Aluminum diamond plate will be used for the floor.
- Smooth aluminum or stainless steel sheet metal will be used for wall and ceiling
- 4" high 3/8" radius aluminum molding extended to the wall will be used
- NSF approved food graded silicon will be used to fill connections of cabinets, walls etc.
- Aluminum diamond plate floor will be welded to fill gaps and connections to make it water resist
- Specification sheet has been attached for all equipment used
- All stainless steel cabinets installed with security latch to ensure doors reliability while moving
- Shurflo water pump will be used model#: 2088-422-144, water delivery range 1.5-2.8 GPM.
- Wash down hose is located under the 3 compartment sink in custom built stainless cabinet. The length of the hose is as long as the truck
- Preparation area is stainless steel smooth and cleanable
- Hand wash sink bowl size is 14" x 10" x 6"
- All appliances are NSF approved (please see NSF letters attached)
- Trailer inside height is 84"
- Shatterproof LED light will be used
- All equipment mounted securely to the framing structure and/or counter top.
- all gas-fired appliances properly insulated in a manner that will prevent excessive heat buildup and/or injury
- All equipment are sealed to floor or have minimum 6" cleaning space under.

# DT-24A Dishwashing Trailer

## 2. Passenger Side Interior View

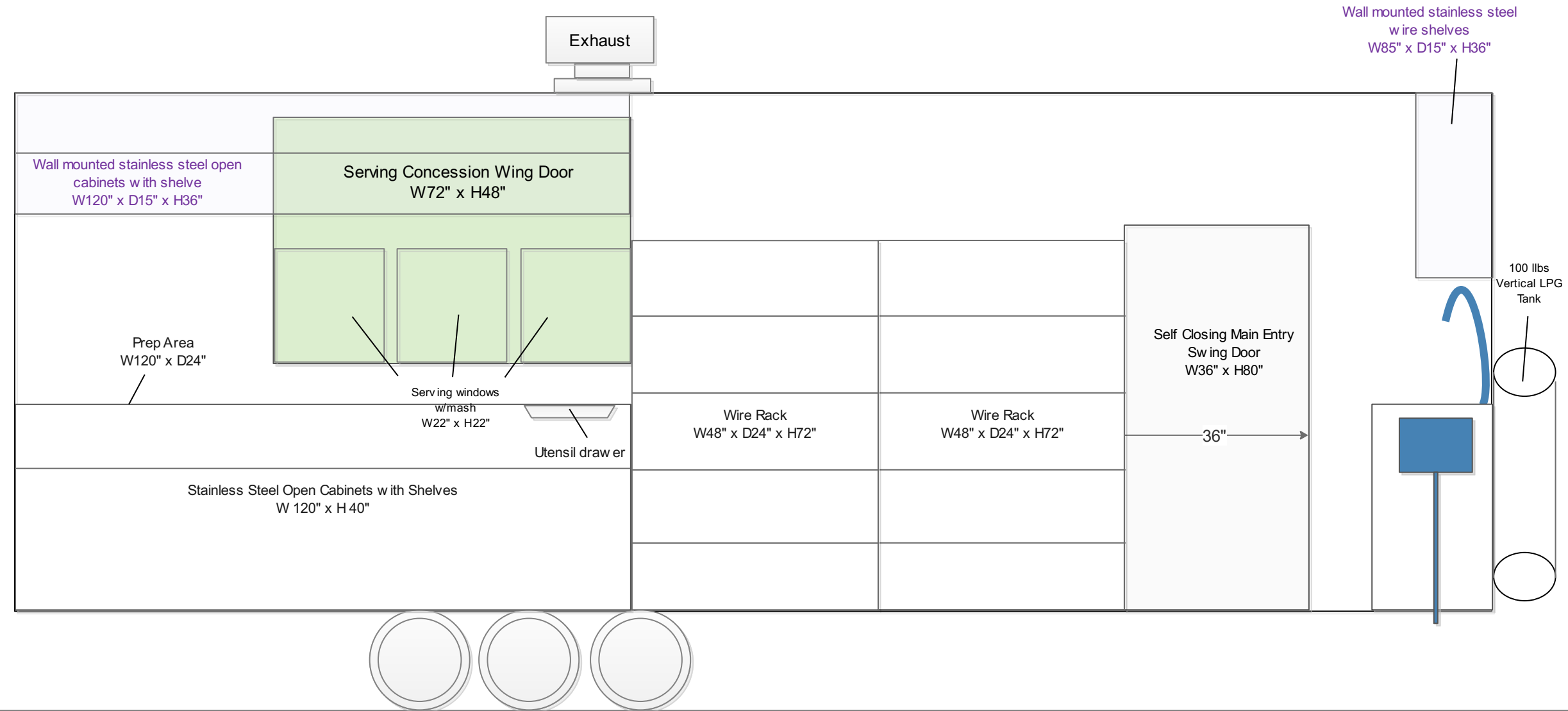

### Description:

- Utensil Drawer is easily cleanable stainless steel material.
- Under sinks area will be covered with stainless steel and door.
- Washdown hose is equipped with pistol grip hose nozzle

3. Passenger Side Exterior View

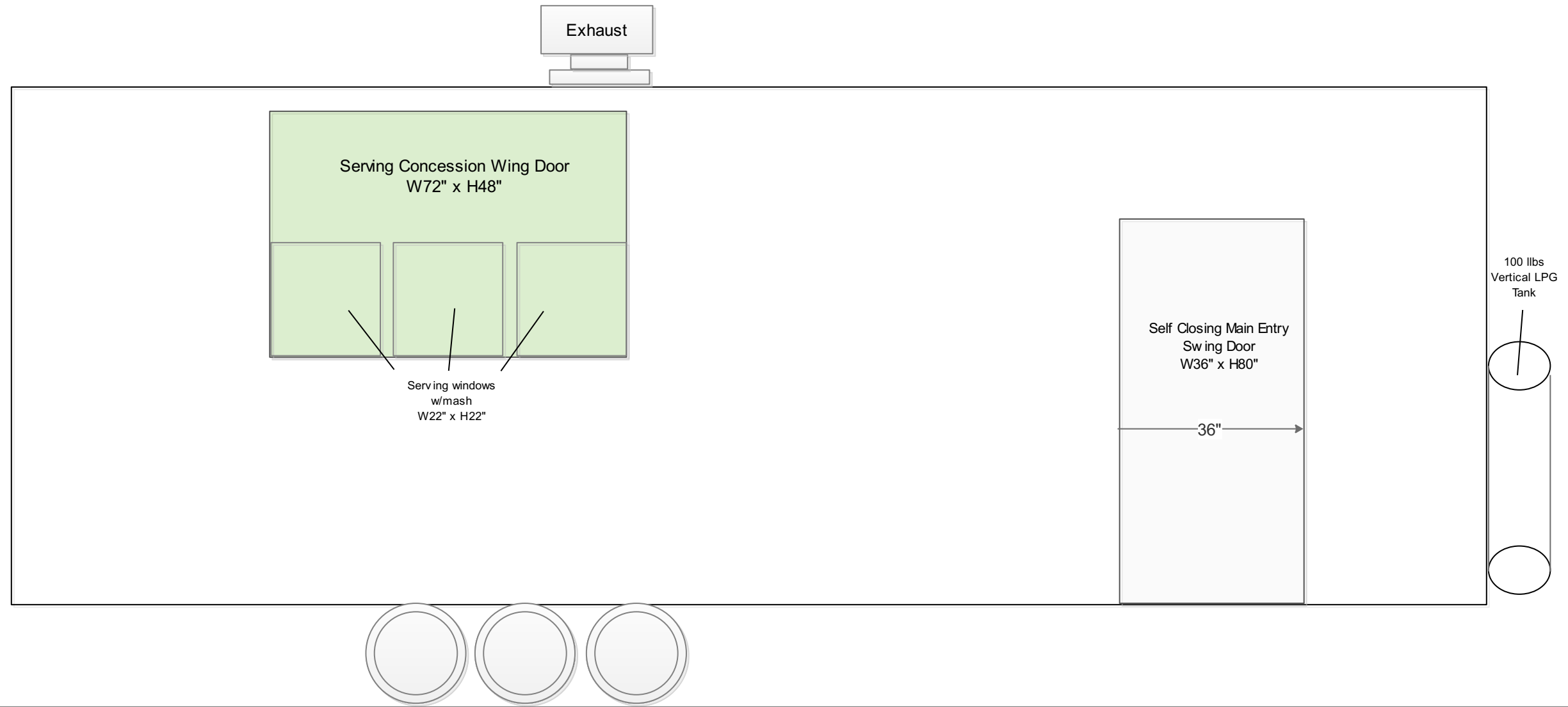

# DT-24A Dishwashing Trailer

## 4. Driver Side Interior View

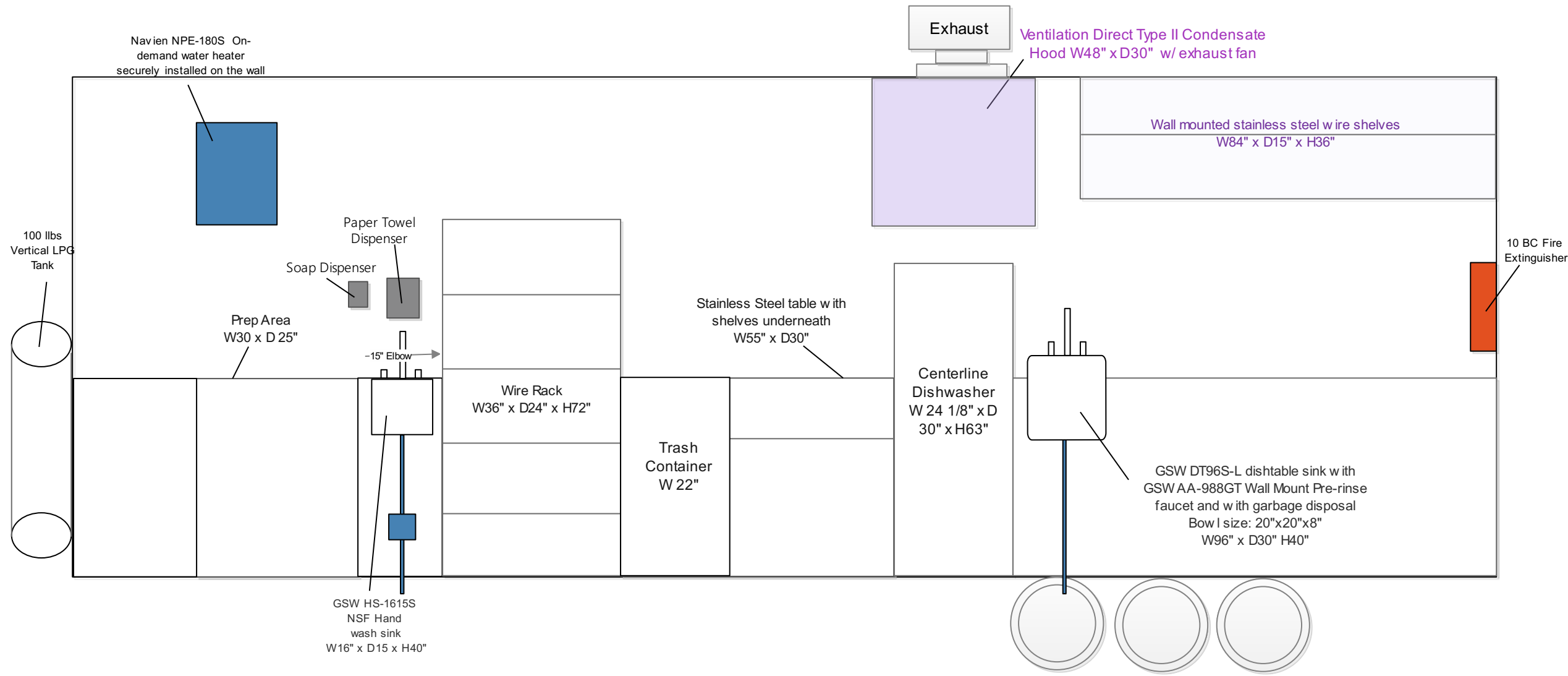

# DT-24A Dishwashing Trailer

## 5. Driver Side Exterior View

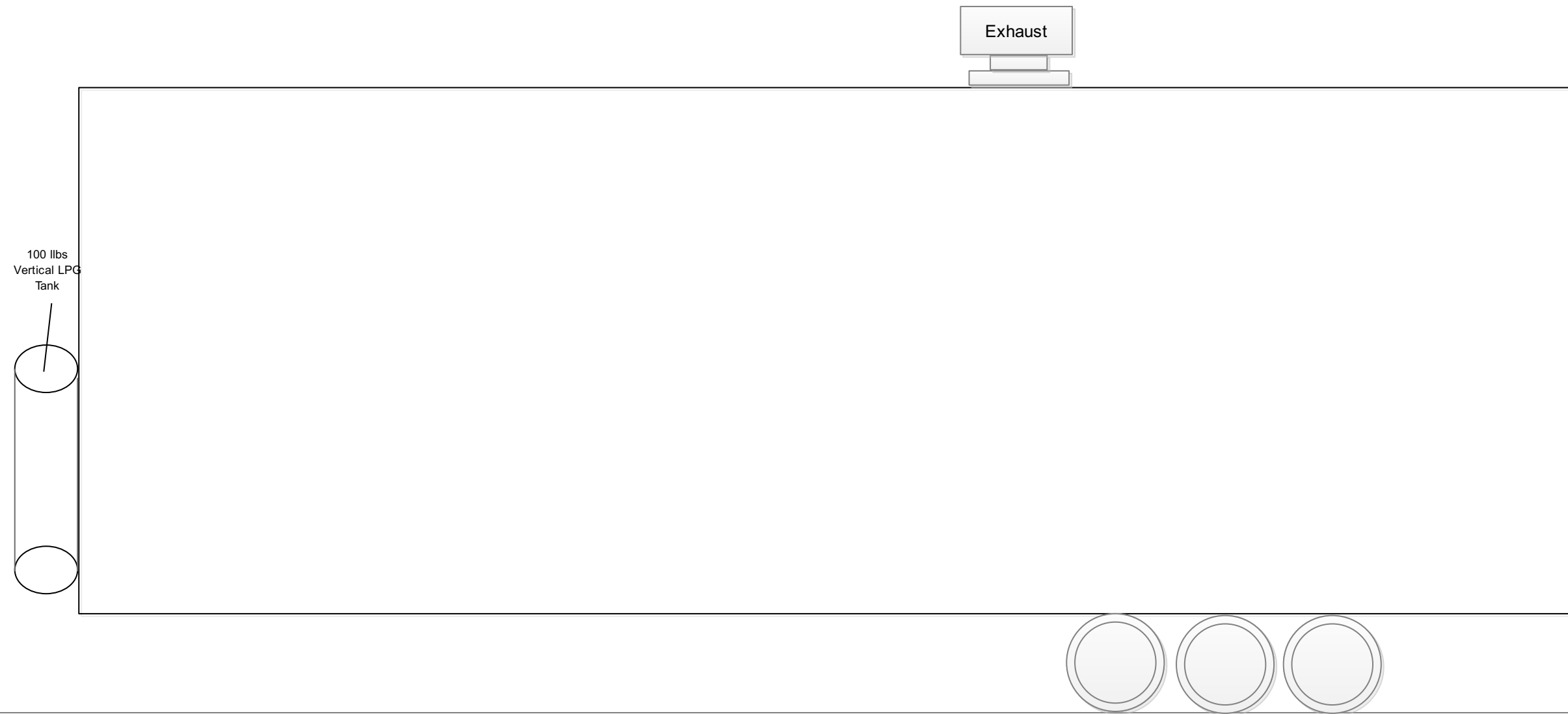

# DT-24A Dishwashing Trailer

## 6. Plumbing View

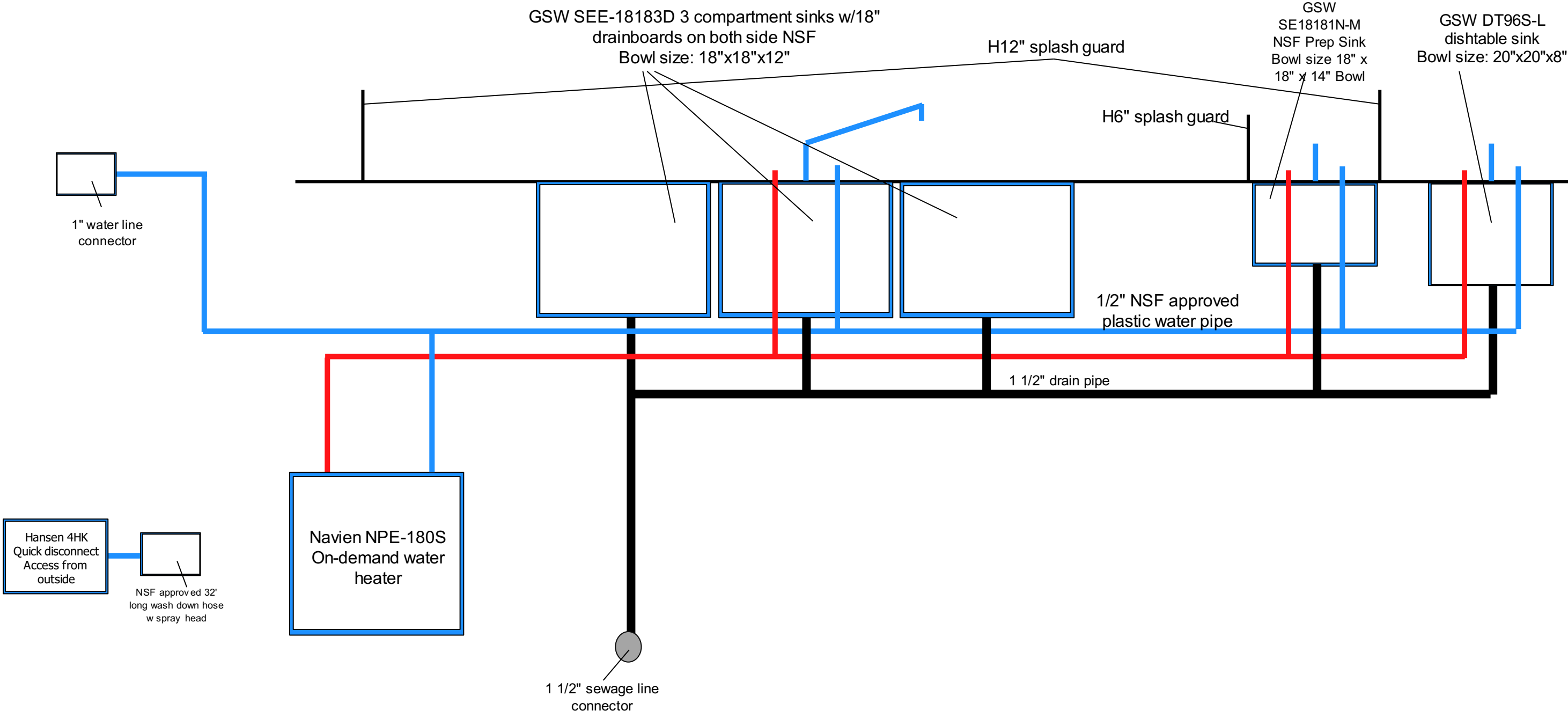

7. Front Side Exterior View

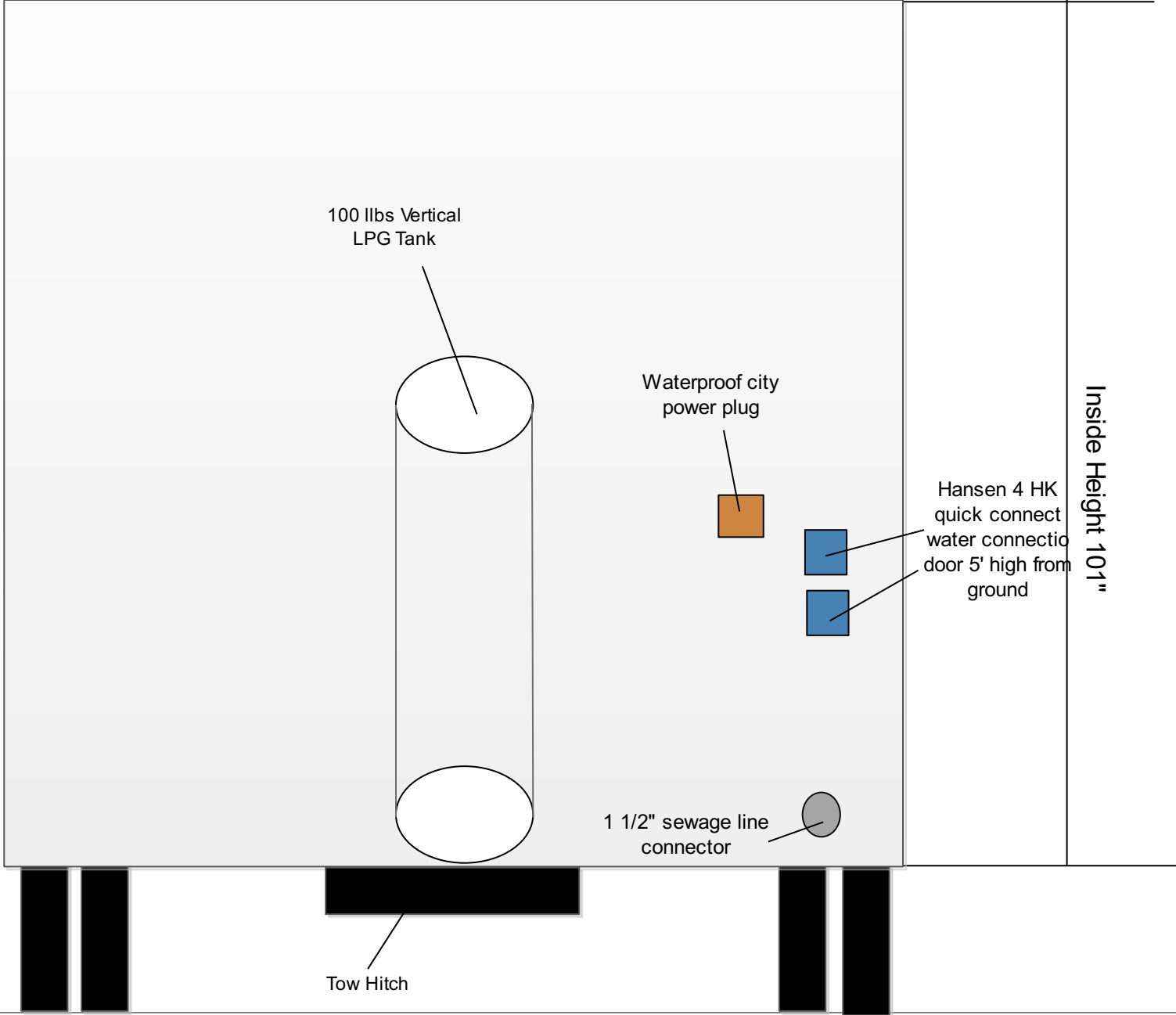

STATE OF CALIFORNIA

THIS VALIDATED PERMANENT TRAILER IDENTIFICATION (PTI) CARD OR A FACSIMILE COPY IS TO BE KEPT WITH THE VEHICLE FOR WHICH IT IS ISSUED. THIS REQUIREMENT DOES NOT APPLY WHEN THE VEHICLE IS LEFT UNATTENDED. IT NEED NOT BE DISPLAYED. PRESENT IT TO ANY PEACE OFFICER UPON DEMAND. PTI IS VALID FOR FIVE (5) YEARS FROM THE DATE OF CONVERSION OR FIRST OPERATION. IF YOU DO NOT RECEIVE A RENEWAL NOTICE, USE A FACSIMILE COPY OF THIS FORM TO PAY YOUR RENEWAL FEES OR NOTIFY THE DEPARTMENT OF MOTOR VEHICLES OF THE NON-OPERATIONAL (PNO) STATUS OF A STORED VEHICLE.

IMMEDIATELY NOTIFY DMV IN PERSON OR BY MAIL ON THE PROPER DMV FORMS WHEN:

- \* YOU CHANGE YOUR ADDRESS.
- \* YOU SELL YOUR TRAILER.
- \* YOU ARE INVOLVED IN AN ACCIDENT (WHETHER OR NOT IT WAS YOUR FAULT) WHEN THERE WAS OVER \$750 DAMAGE OR ANY BODILY INJURY OR DEATH.

WHEN WRITING TO DMV, ALWAYS GIVE YOUR FULL NAME, PRESENT ADDRESS, AND THE VEHICLE MAKE, LICENSE, AND IDENTIFICATION NUMBERS.

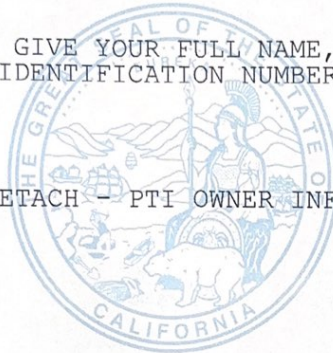

\*\*\*\*\* DO NOT DETACH -- PTI OWNER INFORMATION \*\*\*\*\*

STATE OF CALIFORNIA

PERMANENT TRAILER IDENTIFICATION CARD									
MAKE	YR MODEL	YR 1ST SOLD	VLF CLASS	TYPE VEH	TYPE LIC	LICENSE NUMBER			
KAUF	2024	2024	EP	41F	PA	4WB7191			
BODY TYPE MODEL	MP	MO	AX	WC	UNLADEN WT	VEHICLE ID NUMBER			
UTIL		FF	2	E	05210	7UZEN2422RD006753			
TYPE VEHICLE USE	DATE ISSUED	CC/ALCO	DT FEE RECVD	PIC	USE TAX	EXP DATE: PERM			
TRAILER	06/05/24	40	06/05/24	5	1738				

REGISTERED OWNER  
CALIFORNIA MOBILE KITCHENS  
PO BOX 2307

PASO ROBLES  
CA 93447

AMOUNT DUE	AMOUNT RECVD
\$ 1785.00	CASH : CHCK : 1785.00 CRDT :
	AMOUNT PAID \$ 1785.00

LIENHOLDER



C00 VC8 FF 0178500 0002 CS C00 060524 PA 4WB7191 753





# T.R. ARNOLD & ASSOCIATES, INC.

Form 401  
Issued 03/21/2012  
Revised 05/11/2022

• Engineering • Plan Review • Inspection •

## INSPECTION REPORT

Work Order No. 24-02507

Manufacturer LA Stainless Kings Client No. 7219 Date 6/7/2024  
 Plant Location 8926 Cumanche Ave Chatsworth CA  
 Inspector Greg Edwards Accompanied By: Jukka Horvath  
Otie Horvath  
 Rate of Production 2 Per month Labels Controlled by:  Manufacturer  TRA

**For Office Use only**

Defects Logged   
 Red Tags Logged   
 Inspection Logged   
 Reviewed By \_\_\_\_\_  
 Comments:

**Inspection Emphasis:**

Structural   
 Plumbing   
 Heating   
 Electrical   
 Fire Safety   
 Records   
 Remedial Level: \_\_\_\_\_

**Material Storage**

Lumber   
 Trusses   
 Plywood   
 Particleboard   
 Insulation   
 Doors   
 Windows

Tests Observed	Pass	Fail	N/A
Gas High Pressure	<input type="checkbox"/>	<input type="checkbox"/>	<input type="checkbox"/>
Gas Low Pressure	<input type="checkbox"/>	<input type="checkbox"/>	<input type="checkbox"/>
Electrical Continuity	<input type="checkbox"/>	<input type="checkbox"/>	<input type="checkbox"/>
Electrical Operational	<input type="checkbox"/>	<input type="checkbox"/>	<input type="checkbox"/>
Electrical Polarity	<input type="checkbox"/>	<input type="checkbox"/>	<input type="checkbox"/>
Dielectric Strength <i>ix</i>	<input type="checkbox"/>	<input type="checkbox"/>	<input type="checkbox"/>
Water Supply	<input type="checkbox"/>	<input type="checkbox"/>	<input type="checkbox"/>
DWV	<input type="checkbox"/>	<input type="checkbox"/>	<input type="checkbox"/>
Fixture	<input type="checkbox"/>	<input type="checkbox"/>	<input type="checkbox"/>
Egress Window Operation	<input type="checkbox"/>	<input type="checkbox"/>	<input type="checkbox"/>
Equipment	<input type="checkbox"/>	<input type="checkbox"/>	<input type="checkbox"/>

All Deficiencies Reinspected? Yes  No  N/A

Labeled Yard Units Inspected? Yes  No  N/A

Unlabeled Yard Units - Checked Status of Q.C. Records? Yes  No  N/A

All other units re-inspected for deviations noted on previous 402/s? Yes  No  N/A

Serial # of unit tested 40671

### INSPECT AND RECORD ALL UNLABELED YARD UNITS AND DEVIATIONS ON FORM 401 & 402

STATION	SERIAL NUMBER	MODEL	APPROVAL NUMBER/DATE	DESTINATION
<u>Final</u>	<u>D006753</u>	<u>D.H</u>	<u>VISUAL</u>	<u>Address:</u>
<u>SPCM 40671</u>		<u>Washoe</u>		<u>9150 Hanover Way</u>
		<u>Trails</u>		<u>ATAS Cal Duro CA</u>
				<u>93422</u>
				<u>VINH</u>
				<u>707 EN2422 RD 006753</u>

**THIS INSIGNIA REMAINS PROPERTY OF THE STATE OF CALIFORNIA DEPARTMENT OF HOUSING AND COMMUNITY DEVELOPMENT DIVISION OF CODES AND STANDARDS**

AS EVIDENCED BY THIS INSIGNIA THE MANUFACTURER CERTIFIES TO COMPLIANCE WITH THE CA HEALTH AND SAFETY CODE DIV. 13, PART 2 AND CA CODE OF REGULATIONS TITLE 25, CHAPTER 3 FOR SPECIAL PURPOSE COMMERCIAL MODULAR CONSTRUCTION. A SPECIAL PURPOSE COMMERCIAL MODULAR BEARING A DEPARTMENT INSIGNIA SHALL NOT HAVE ITS FIRE AND LIFE SAFETY, PLUMBING, ELECTRICAL, OR MECHANICAL EQUIPMENT OR INSTALLATIONS ALTERED OR CONVERTED UNLESS APPROVAL IS FIRST OBTAINED FROM THE DEPARTMENT.

**SELLER CERTIFIES TO COMPLIANCE**

**SPCM 40671 D006753**





# T.R. ARNOLD & ASSOCIATES, INC.

• Engineering • Plan Review • Inspection •

## INSPECTION OBSERVATION REPORT

LA stainless King      Chatsworth CA      6/7/2024  
 MANUFACTURER AND PLANT LOCATION      Date

Page 2 Of 2

SERIAL NUMBER	DAPIA/CCI/MCI CODE REF.	OBSERVATIONS/COMMENTS
100673		This inspection is for the state of California spec.
		This unit is for emergency diversion relief. This unit only washes dishes. There is no fresh water or gray water tanks due to the high volume of water needed for cleaning dishes, it will be hooked up to <del>water</del> utilities when in use.
		Checked sinks Dishwasher Gal Base disposal tankless water heater main electrical panel.
	MCI	Deficiencies:
1)	51.1	per the manufacturers instructions the air intake and the exhaust for tankless water heater waste close 3 inches apart they need to be 36 inches. Has not fixed and remain.

I have reviewed the issues presented and instituted procedures for correction of non-conforming items.

Otil Horvath

Manufacturers Representative

The above report is a true and accurate account of the issues noted to the best of my knowledge.

J. Edwards

Inspector

Time In 11:00

Time Out 1:00

Inspection time 2 HRS