

KT-320 Trailer

1. Top View

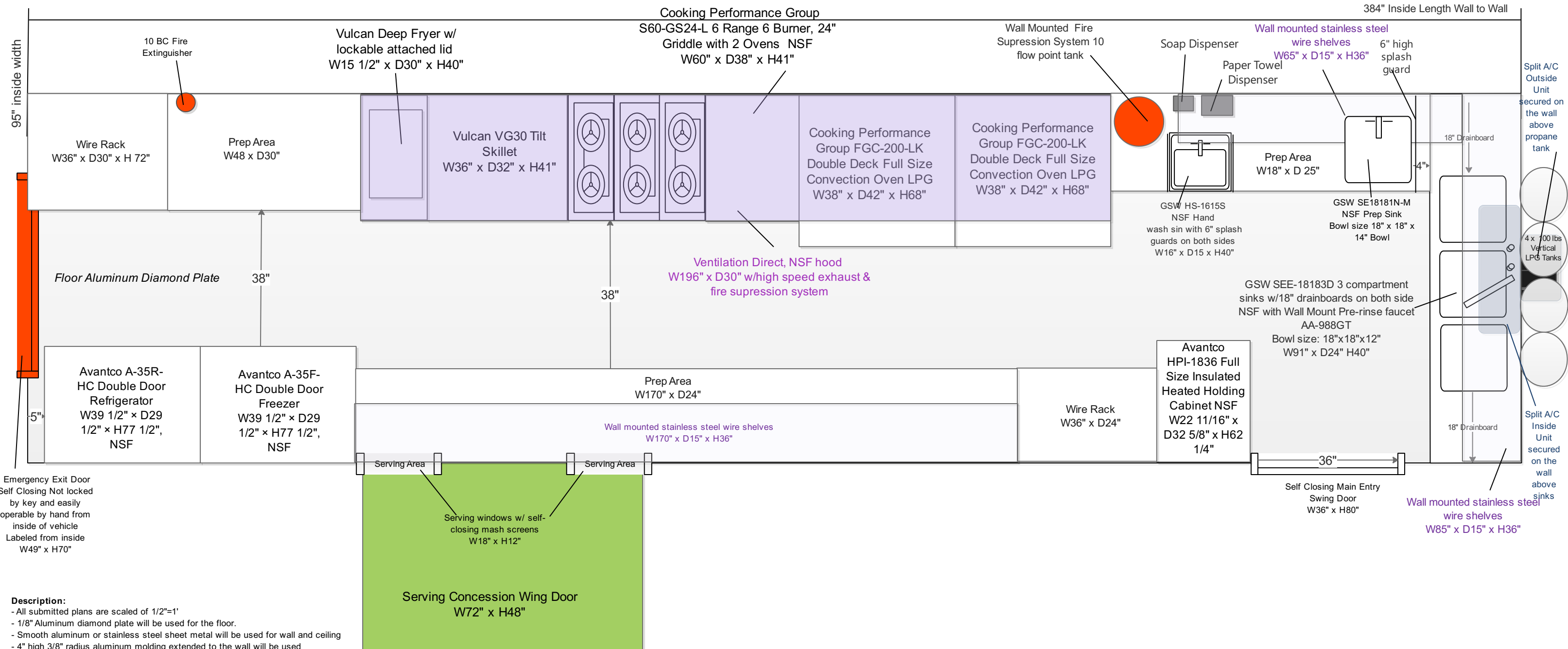

Description:

- All submitted plans are scaled of 1/2"=1'
- 1/8" Aluminum diamond plate will be used for the floor.
- Smooth aluminum or stainless steel sheet metal will be used for wall and ceiling
- 4" high 3/8" radius aluminum molding extended to the wall will be used
- NSF approved food graded silicon will be used to fill connections of cabinets, walls etc.
- Aluminum diamond plate floor will be welded to fill gaps and connections to make it water resist
- Specification sheet has been attached for all equipment used
- All stainless steel cabinets installed with security latch to ensure doors reliability while moving
- Shurflo water pump will be used model#: 2088-422-144, water delivery range 1.5-2.8 GPM.
- Potable water inlet is 1" above overflow
- 196" Type I hood has been provided
- Utensil drawer is smooth and has rounded corners and can be easily pull out for cleaning
- sanitizing buckets are mounted to the cabinet shelve and they have covers to prevent spillage while vehicle is in motion
- Wash down hose is located under the 3 compartment sink in custom built stainless cabinet. It is not located above any food equipment. The length of the hose is as long as the truck
- Preparation area is stainless steel smooth and cleanable
- Hand wash sink bowl size is 14" x 10" x 6"
- All appliances are NSF approved (please see NSF letters attached)
- Trailer inside height is 84"
- Shatterproof LED light will be used
- All equipment mounted securely to the framing structure and/or counter top.
- all gas-fired appliances properly insulated in a manner that will prevent excessive heat buildup and/or injury
- All units will be build to the Los Angeles County Health Code requirement
- All equipment are sealed to floor or have minimum 6" cleaning space under.

KT-32N Trailer

2. Passenger Side Interior View

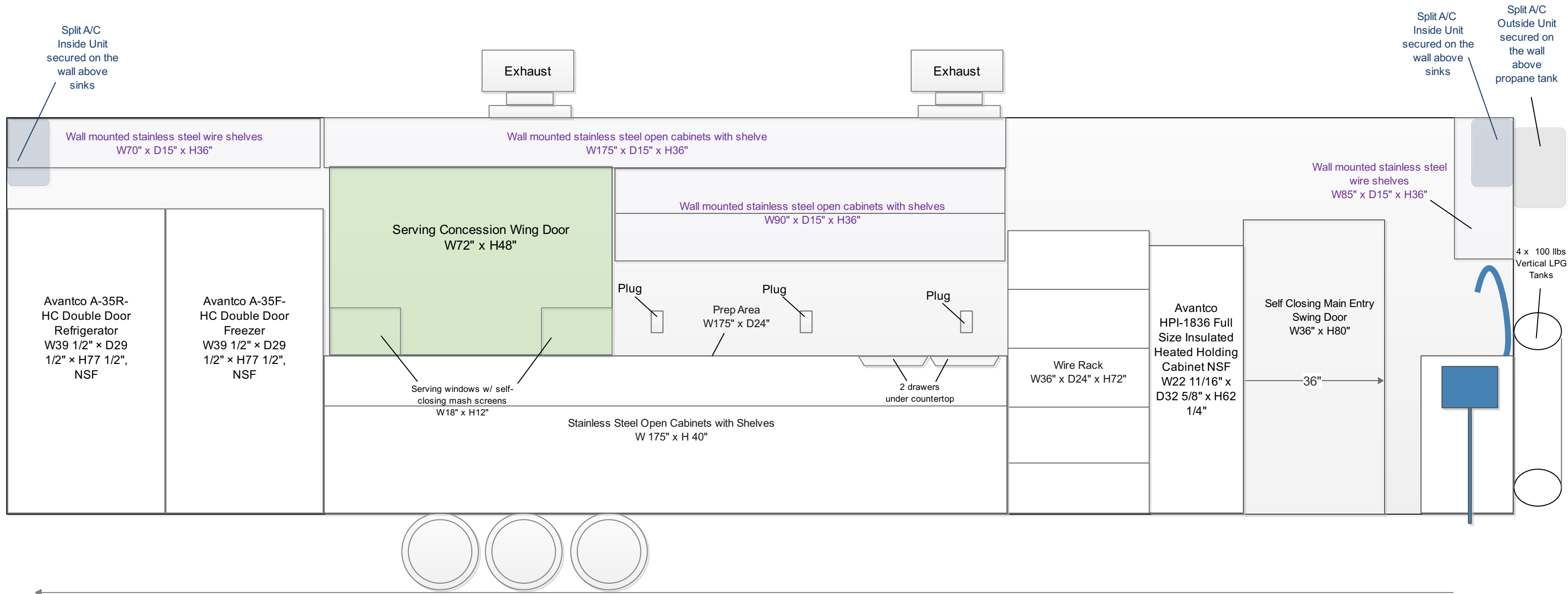

Description:

- Utensil Drawer is easily cleanable stainless steel material.
- Under sinks area will be covered with stainless steel and door.
- Washdown hose is equipped with pistol grip hose nozzle

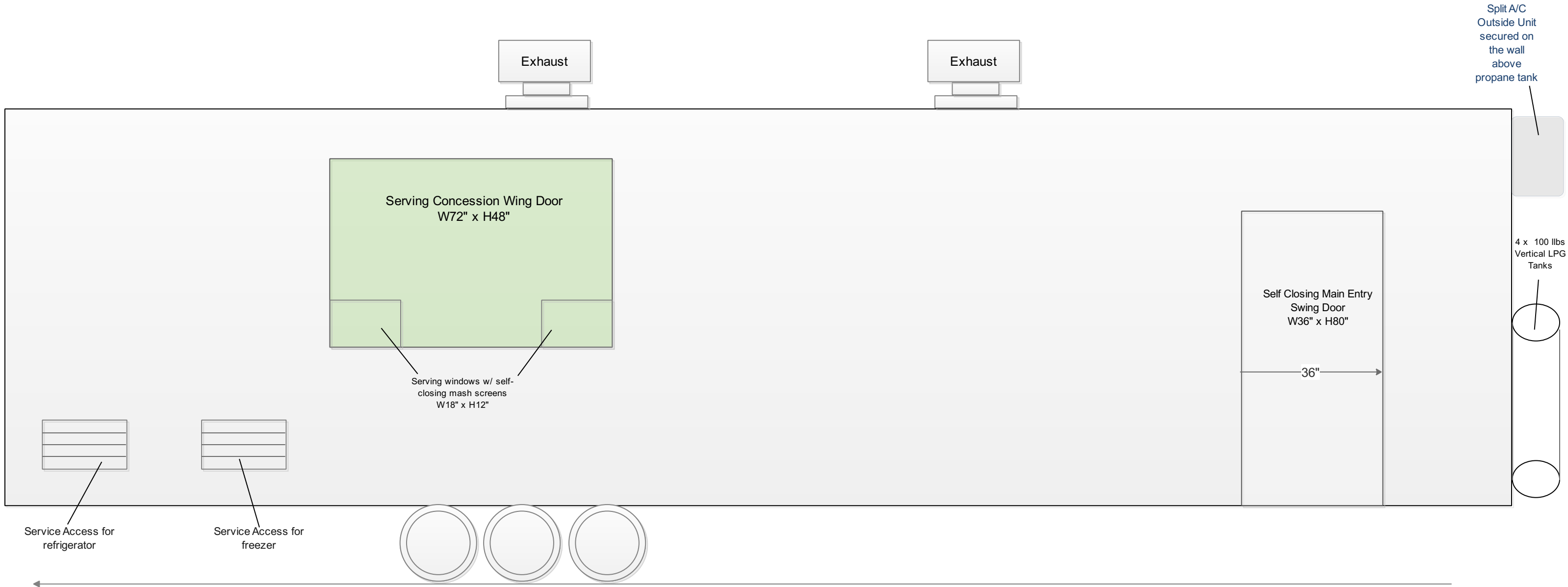



Item No.: _____

Order No.: _____

Qty: _____ Date: _____

THREE COMPARTMENT SINK WITH TWO DRAIN BOARDS

Features

- 16 or 18 gauge stainless steel
- Three tubs sink with two drain boards
- 8" wall mounted faucet holes
- Polished finish stainless steel
- Stainless steel legs with cross bracing
- Extra welded under tubs for longevity
- Strainers included, opening diameter 3-5/8"
(Except SE10143D strainer opening diameter 1-7/8")

Suggested Accessory:

AA-7xxG



AA-8xxGS



Plan View

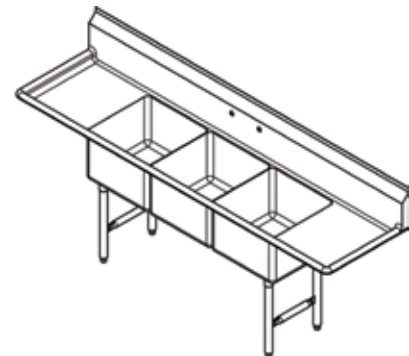
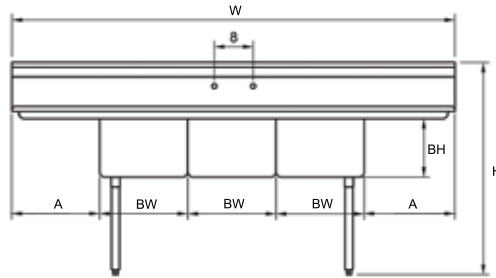
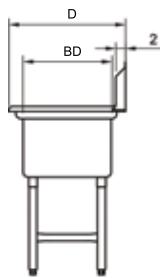

Order No.	Gauge	D x W x H (in)	BD x BW x BH (in)	A (in)	G. W. (lb)
SE10143D	18	21 x 54-3/8 x 41	14 x 10 x 10	12	48
SE15153D	18	21 x 75-3/8 x 45	15 x 15 x 10	15	70
SE16203D18	18	26 x 84-3/8 x 45	20 x 16 x 12	18	84
SE16203D24	18	26 x 96-3/8 x 45	20 x 16 x 12	24	88
SE18183D	18	24 x 90-3/8 x 45	18 x 18 x 12	18	91
SEE18183D	18	24 x 90-3/8 x 45	18 x 18 x 12	18	88
SE18183D20	18	24 x 94-3/8 x 45	18 x 18 x 12	20	93
SE18183D24	18	24 x 102-3/8 x 45	18 x 18 x 12	24	96
SH18243D	16	30 x 90-3/8 x 45	24 x 18 x 14	18	125
SHH18243D	16	30 x 90-3/8 x 45	24 x 18 x 14	18	123
SH18243D24	16	30 x 102-3/8 x 45	24 x 18 x 14	24	130
SH20203D	16	26 x 100-3/8 x 45	20 x 20 x 14	20	112
SH20243D	16	30 x 100-3/8 x 45	24 x 20 x 14	20	136
SHH20243D	16	30 x 100-3/8 x 45	24 x 20 x 14	20	132
SH20283D*	16	34 x 100-3/8 x 45	28 x 20 x 14	20	145
SHH20283D*	16	34 x 100-3/8 x 45	28 x 20 x 14	20	140
SH24243D*	16	30 x 120-3/8 x 45	24 x 24 x 14	24	155
SHH24243D*	16	30 x 120-3/8 x 45	24 x 24 x 14	24	151

Models marked with * have two sets of faucet holes.

KT-32N Trailer

4. Driver Side Interior View

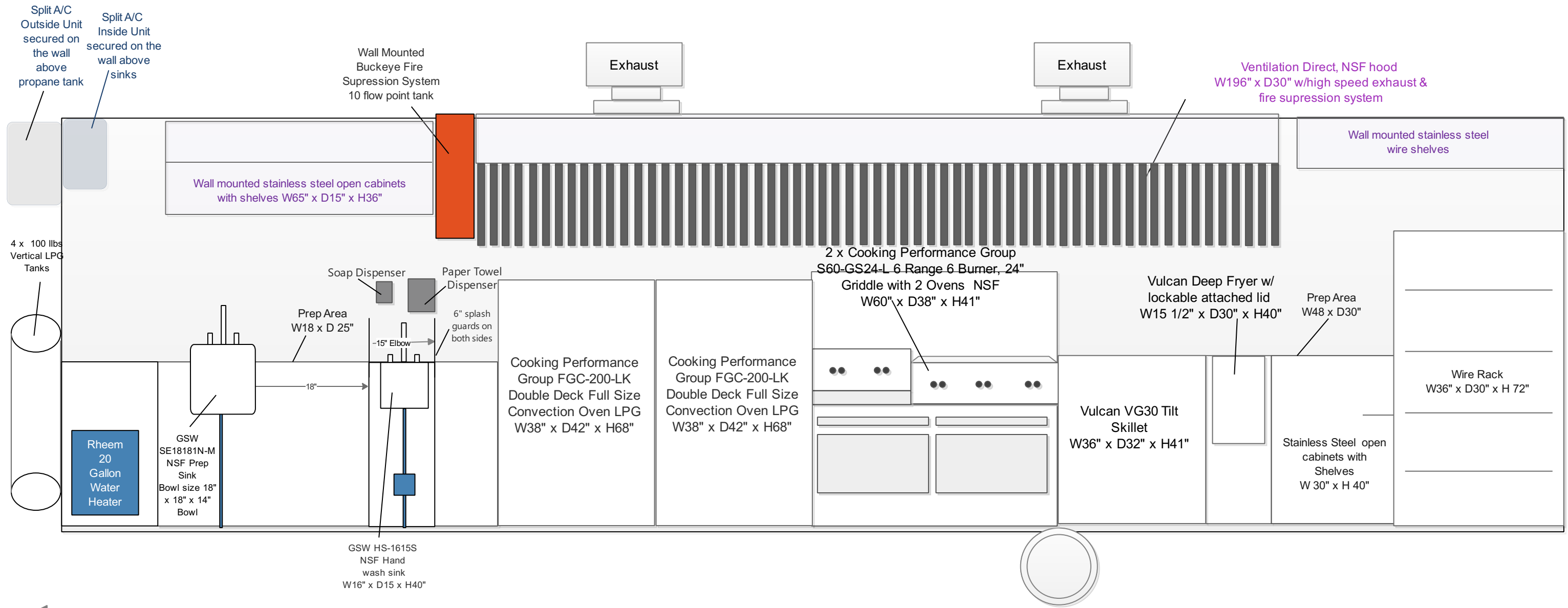

KT-32N Trailer

5. Driver Side Exterior View

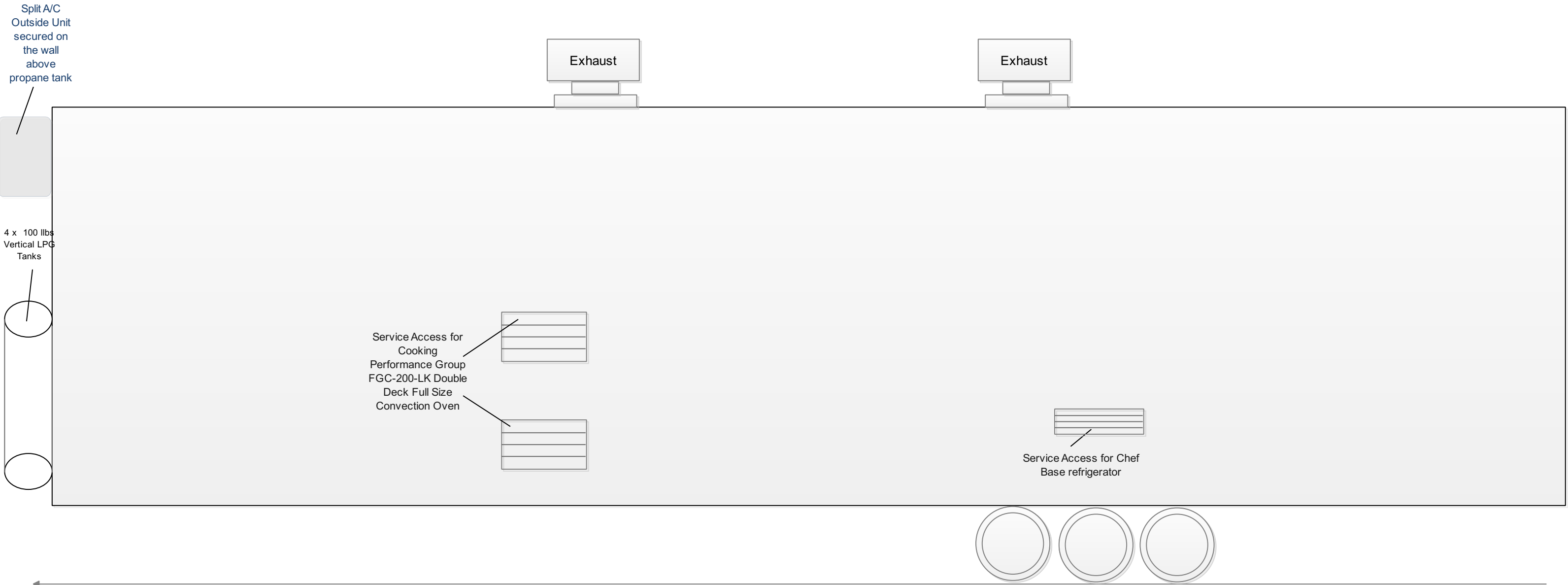

6. Plumbing View

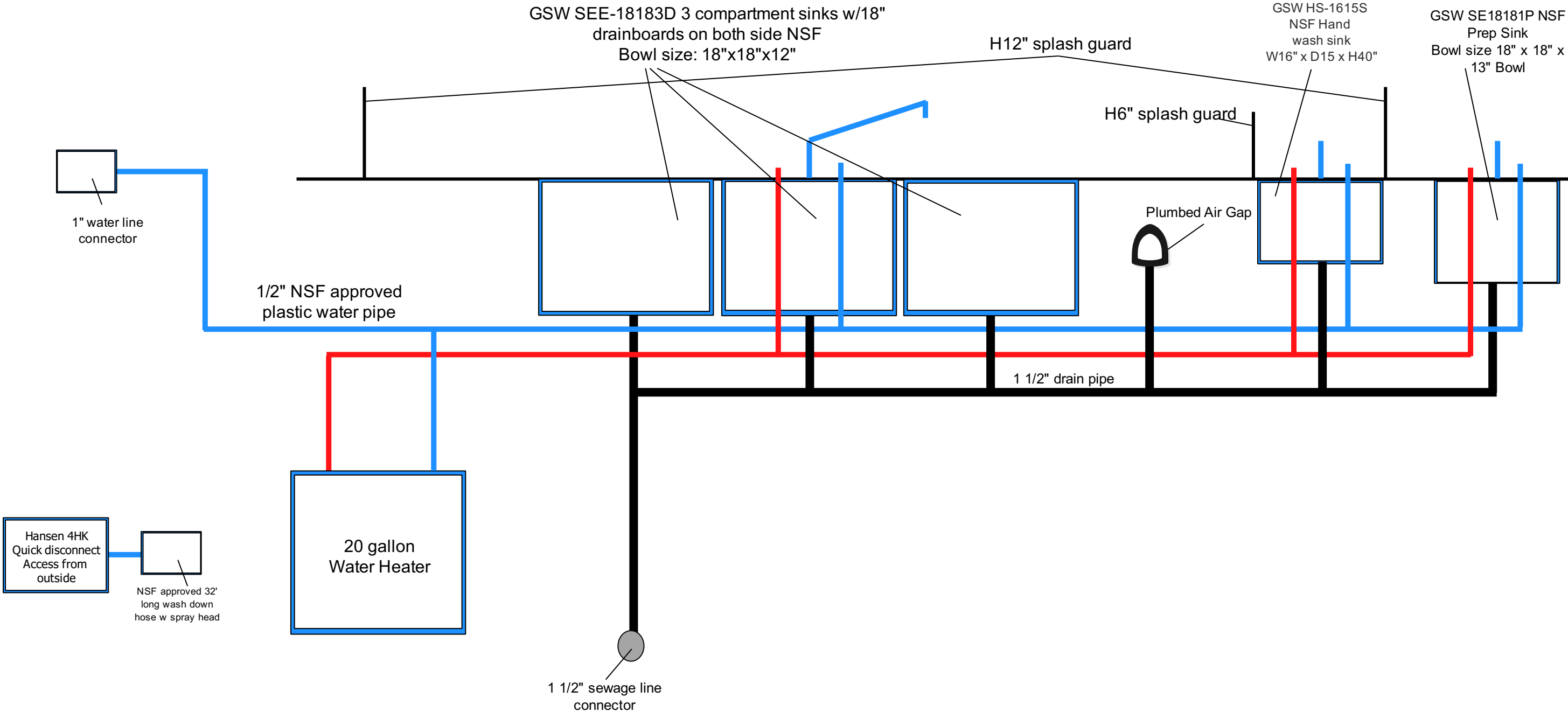

7. Front Side Exterior View

